

# A Computer-Aided Bibliometrics System for Journal Citation Analysis and Departmental Core Journal Ranking List Generation

## Yih-Chearng Shiue

Professor  
Department of Information Management, National Central University  
Tao-Yuan, Taiwan  
E-mail: yeshiue@mail.oop.gov.tw

## Ray-I Chang

Assistant Professor  
Department of Engineering Science & Ocean Engineering, National Taiwan University  
E-mail: rayichang@ntu.edu.tw

## Gen-Ming Guo

Ph.D. Student  
Department of Information Management, National Central University  
Tao-Yuan, Taiwan  
E-mail: openfind@mgt.ncu.edu.tw

## Abstract

*Due to the tremendous increase and variation in serial publications, faculties in department of university are finding it difficult to generate and update their departmental core journal list regularly and accurately, and libraries are finding it difficult to maintain their current serial collection for different departments. Therefore, the evaluation of a departmental core journal list is an important task for departmental faculties and librarians. A departmental core journal list not only helps departments understand research performances of faculties and students, but also helps librarians make decisions about which journals to retain and which to cancel. In this study, a Computer-Aided Bibliometrics System was implemented and two methodologies (JCDF and LibJF) were proposed in order to generate a departmental core journal ranking list and make the journal citation analysis. Six departments were taken as examples, with MIS as the major one. One journal citation pattern was found and the ratio of Turning point-to-No. journal was always around 0.07 among the 10 journals and 6 departments. After comparing with four methodologies via overlapping rate and standard deviation distances, the two proposed methodologies were shown to be better than questionnaire and library subscription method.*

**Keywords:** Computer-aided bibliometrics system; Departmental core journal; Citation analysis; Bibliometrics; Journal ranking

## Introduction

The tremendous increase in the number of serial publications, coupled with

JOEMLS

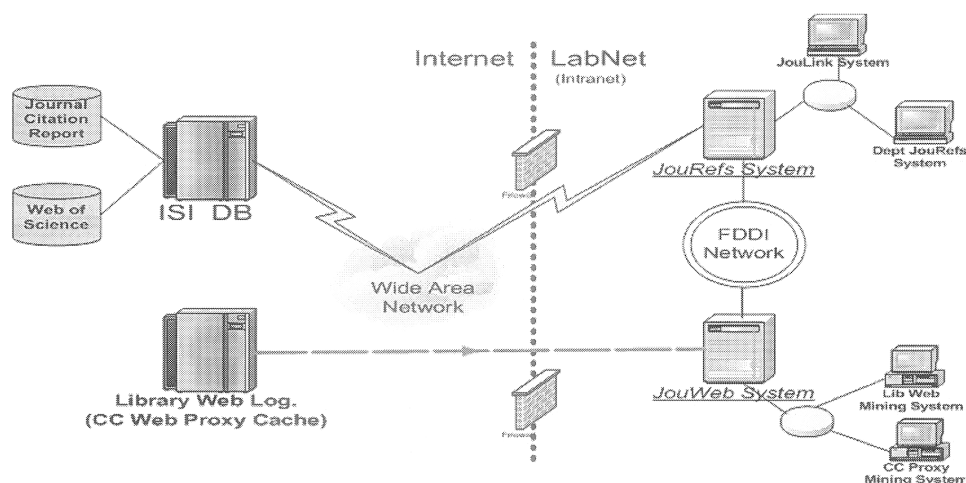
spiraling subscription costs and shrinking library budgets, are driving what many describe as the “crisis in scholarly publishing” (Kobulnicky, 1977). And the impact of every journal to department is variable all the time. While faculties are finding it impossible to update their departmental core journal list regularly and accurately, libraries are finding it increasingly difficult to maintain their current serial collection which is suitable for each department, let alone acquire new titles. The evaluation of serial journals for generating and ranking departmental core journal lists becomes a very challenging task for departmental faculties and librarians. There are several uses for a departmental core journal ranking list. Firstly, it can help librarians evaluate the adequacy of their institution’s collection and make decisions about which journals to retain and which journals to cancel. Secondly, it is useful to help departmental faculties regularly evaluate and modify their current departmental core journal ranking list. This list not only helps graduate students and junior researchers to understand the journal citation network for their own department, but also helps departments to understand members’ research performance.

In previous studies, Bill developed a MIS department core journal collection by questionnaire (Bill, 1997). The major drawback for this is that the most scholars knew only best known journals but were not as familiar with other related journals, and personal impression are also a limitation. The staff of Florida State University proposed an academic medical library core journal collection (Barbara, 2003). For this, they created a core list by analyzing print journal subscription lists of 18 academic medical libraries with missions similar to the community-based FSU College of Medicine. However, if some journals were subscribed to all libraries or some were not, that would be difficult to rank all journals. Janice and John tried to define an undergraduate core journal collection (2002). They used three methodologies including in expert list, full-text aggregator databases and a journal access core collection system (JACC) developed by California State University. However, an expert list has the same problem as questionnaire; and overlapping journal titles from full-text aggregator databases or JACC cannot rank every journal. That is why those authors only list core journal instead of ranking core journals.

In order to generate a departmental core journal ranking list, for which every journal can be ranked by its own impact weights and not be affected by personal impressions or biases, we propose two methodologies and develop a Departmental Computer-Aided Bibliometrics System (DCABS) to generate a departmental core journal ranking list (Figure 1). Firstly, the journal citation analysis method and JouRefs system can automatically parse journal citations from articles at a large scale. Research articles in the same department are the materials for the DCABS system. This approach can process a huge number of journals and produce factors/weights for them to be ranked, thus overcoming the above limitations.

Secondly, both the Library web log analysis method and the JouWeb system can get journal query frequency from on-line readers belonging to the same department, and produce factors or weights for further journal analysis and ranking.

Through overlapping ratio and average standard deviation distances between journal lists, we show that our methodologies are better than both questionnaire and library subscription methods. Via our proposed approaches and systems, some interesting extended analysis were developed, such as individual and accumulated journal analysis, journal overlapping analysis, as well as journal cited/citing analysis. Additionally, a citation pattern was found among all journals and departments, for which 10 core journals from MIS department and six different departments were taken as input samples. The graph of accumulated citations for each journal and department has a stable turning point. For all 10 journals and 6 departments which we studied, the TJ ratios (turning point / citing journals) are all equal to 0.07 and the TP slopes (the slope from turning-point to starting-point) are all around 12.



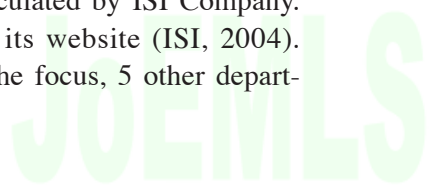
**Figure 1 Departmental Computer-aided Bibliometrics System**

### Materials and Methods

This study conducted a survey by using Web of Science (WOS), Journal Citation Report (JCR), NCU Library Web log and Web Proxy Cache to generate a departmental core journal list.

#### ISI Database

For WOS and JCR databases which are maintained by ISI (*Institute of Science Information*) were the major sources for this experiment. WOS collects the journal articles' cited references. JCR collects the journal impact factor, which is composed of journal ranking indicators which are defined and calculated by ISI Company. Detailed formulas and information can be reached at its website (ISI, 2004). Although the MIS department of this experiment was the focus, 5 other depart-



ments were also chosen in order to compare their differences: Library and Information Science (from 2001/01 to 2004/04), Management Information Systems (from 2001/01 to 2004/04), English (from 2003/01 to 2003/12), Computer Science (from 2004/04/16 to 2004/04/30), Mechanical Engineering (from 2004/04/16 to 2004/04/30) and Life Science (from 2004/01 to 2004/04). Owing to the difference among academic community population, we choose suitable time periods in order to let the numbers of papers from each set of journals to be much closer.

As for the individual and accumulated journal analysis, 10 kinds of MIS journals were selected from Hwang (2001) in the first step. Then we retrieved cited and citing references from above ISI Database. Table 1 is the codename for abbreviations and full journal title exchange, which are used later. Additionally, the time periods for all journals are all between 2000 January and 2004 April. The maximum number of articles in these journals is 5442 in the Management Science journal, the minimum number is 1608 in the MIS Quarterly journal and the average is 3396.

**Table 1 Codename for Abbreviation and Full Journal Titles**

Abbreviation	Full Journal Title	Abbreviation	Full Journal Title
<i>MS</i>	<i>Management Science</i>	<i>OrgSCI</i>	<i>Organization Science</i>
<i>MISQ</i>	<i>MIS Quarterly</i>	<i>ASQ</i>	<i>Administrative Science Quarterly</i>
<i>IEEE T. SE</i>	<i>IEEE Transaction on Software Engineering</i>	<i>I&amp;M</i>	<i>Information &amp; Management</i>
<i>ISR</i>	<i>Information System Research</i>	<i>DS</i>	<i>Decision Science</i>
<i>JMIS</i>	<i>Journal of Management Information Systems</i>	<i>DSS</i>	<i>Decision Support System</i>

### **NCU library-web-log and web-proxy-cache**

The National Central University (NCU) library webpage provides a journal search engine, which records visitors on-line activities to a log file (NCU, 2004). The total raw records are 2,771,270 and file size is 300MB. Its time period is from 2003 Aug. to 2004 Mar. The NCU Web Proxy log records outgoing activities for web visits from 2003 October to 2003 December including almost 600 million records in file size of 135GB.

### **Methods**

The Departmental Computer-Aided Bibliometrics System (DCABS) was constructed via Microsoft Visual C++.net and SQL Server 2000 on a Windows 2000 platform. Source Codes are available at <http://www.openfind.idv.tw>. The DCABS is divided into the two major sub-systems of JouRefs and JouWeb, which this system architecture can be seen at Figure 1.

### **JouRefs System**

There are two sub-modules in JouRefs system, JouLink and **DeptJouRefs**. The JouLink processes journal cited/citing frequencies among journals. First, we export citations of articles from 10 journals in WOS. Second, raw data of citations were input into system. JouLink parses the articles, calculates frequency and obtain the ISSN from our own customized ontology table/database. Finally, properties like journal name, citing/cited frequency, ISSN or impact factor are retrieved and calculated for the complete list of 10 journals. The **DeptJouRef** system's operation procedure is similar with JouLink, with only difference being that you should export citations data from WOS via department keyword (ex: Dept Management Information System). Through the **DeptJouRef** system, one table for journal citation frequencies of the MIS department can be obtained. After getting these purified data, further journal cited/citing, overlapping and clustering analysis can then be applied. Finally, one departmental core journal collection/list is generated and ranked by the Journal Cited Factor (JCDF), which we develop and use in the **DeptJouRef** system.

### **JouWeb System**

The JouWeb System is composed of the Lib Web Mining System (LibWeb) and the CC Proxy Mining System (CCProxy). LibWeb is only assembled by our customized SQL commands and store procedures based on SQL Server2000. So it does not currently C++ codes to finish jobs automatically. The workflow for LibWeb is to begin by importing the library web server log, and journal name frequency is purified from the database. Then noises coming from different departments, multiple accesses by single user and similar journal names are eliminated. Finally, a departmental core journal ranking list will be generated by letting querying frequency for the base journal divide number of articles published by the same base journal, yielding a factor called LibJF, which is used in the JouWeb system. The CCProxy System handles the Squid Cache (2004) of the web proxy server, which first builds a journal hyperlink list for journals of interest. Then CCProxy System automatically outputs an access frequencies table for the input journal list. We suppose a journal ranking list could be generated by this. Unfortunately, most researchers remove proxy access setting options while they access the internet, even when they are using internet for other purposes. The results from this material is depressed us. Thus the results from this material are not very useful.

## **Results and Discussions**

The results were analyzed and discussed in the following four parts: 1. individual and accumulated journal citation analysis, 2. journal overlapping analysis, 3. journal cited/citing analysis, and 4. departmental core journal analysis.

### Individual and accumulated journal citation analysis

Bradford's Law (1948, 1934) is a well known law which is widely applied to the journal distribution study for specific research topic. Bradford found that there were a few journals that covered most topics when he studied the fields of Applied Geophysics and Lubrication. After calculating the accumulated articles, he segmented the journals into three parts with equal amounts of quantity and used logarithms to calculate them. The ratio among three areas was (Figure 2). Brookes

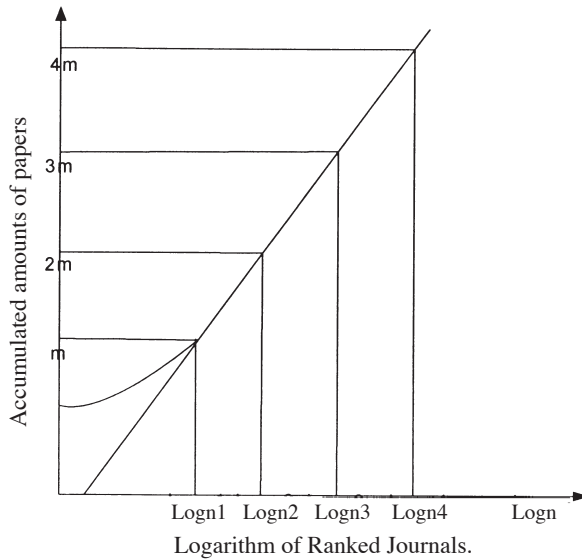


Figure 2 Bradford's Law(1948)

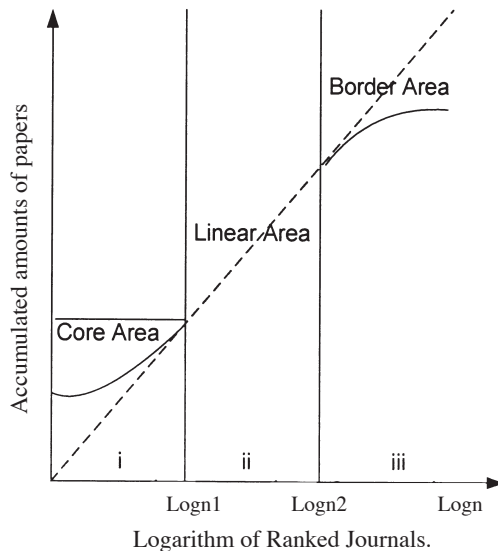


Figure 3 Bradford-Zipf Law(1968)

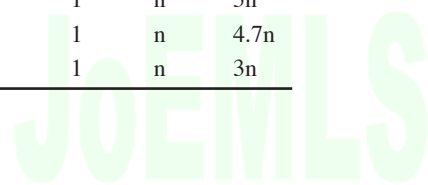
extended this law to Zipf’s Law (Zipf, 1949) and called it the Bradford-Zipf Law (Brookes, 1968). This rule indicates that the journal distribution is close to an S curve (Figure 3), and not linear.

In this paper, we applied both the Bradford and the Bradford-Zipf Law to analyze departmental core journal distribution. There are two major differences between this study and previous work. The first is in terms of the materials, since we focus on the reference citations between journals, and not only the appeared frequencies of journal title. The second is that our theme is according to department instead of topic. Although some parts of our processes are similar to Bradford and Brookes, but we differ totally in the aspects of materials, methods and themes. Comparing with the Bradford’s Law, our individual journal citation ratio distribution for three areas is. As for accumulated journals, the ratio for three areas is. These ratios are in the same, but they do not have fixed ratios. This is very different from Bradford’s Law. Table 2 and Table 3 were generated from different of sub-programs in JouLink system. The work to accumulate every journal’s citations can not be achieved by summarizing journals’ citations in Table 2 directly. It needs software to assist with matching journal name and adding citation counts for each journal, otherwise it would need lots of manual works to align every journal and record its citations step by step for ten journals. That is why we design another sub-program in order to generate Table 3. Related raw datasets can be obtained at supplementary website and the accumulated results for every step can be seen from ten excel files.

After ten journals were processed by the JouLink system, it was found that the accumulated citations for all journals have similar pattern, shown in Figure 4-5. Taking Management Science journal as example, the X-axis is the number of journals and the Y-axis is the accumulated citation frequency. After passing the turn-

**Table 2 Individual Journal Citation Ratio Distribution**

Individual	TotalCites	SubCites1	SubCites2	SubCites3	Cites1	Cites2	Cites3
<i>I&amp;M</i>	14574	4858	9716	14574	1	n	8.9n
<i>MS</i>	16906	5635	11270	16906	1	n	8.8n
<i>OrgSCI</i>	10259	3420	6840	10259	1	n	7n
<i>DS</i>	6603	2201	4402	6603	1	n	7n
<i>MISQ</i>	4644	1548	3096	4644	1	n	6.8n
<i>AMR</i>	8531	2843	5687	8531	1	n	6n
<i>JMIS</i>	6930	2310	4620	6930	1	n	5.6n
<i>ASQ</i>	5268	1756	3512	5268	1	n	5.4n
<i>IEETSE</i>	18538	6179	12358	18537	1	n	5n
<i>ISR</i>	4217	1406	2812	4217	1	n	4.7n
<i>DSS</i>	5458	1816	3632	5458	1	n	3n

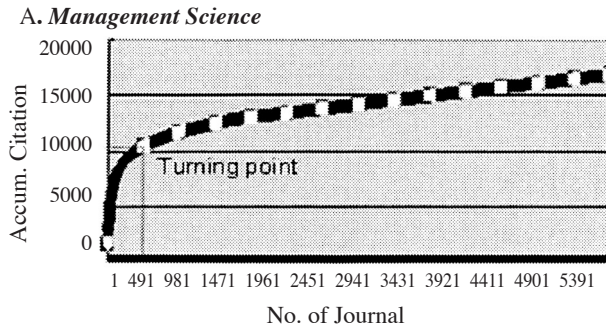




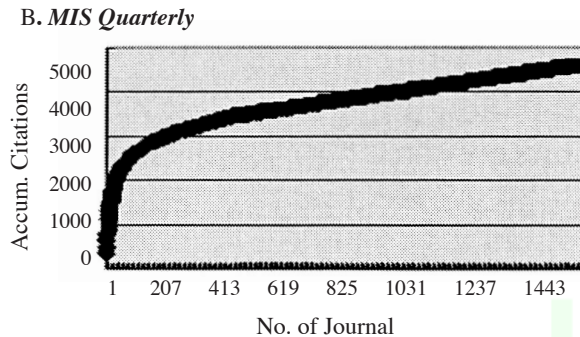
ing-point of 392 on the X-axis, the curve or slope does not grow significantly. The turning point to No. journal Ratio (TJ Ratio), Citing Frequency to Total Citing Ratio (CT Ratio) and Turning Point Slope (The Slope from Turning Point to Starting Point) are all shown in Table 4. The Starting Point means Top 1 journal's cited counts, which this journal have the most highest cited frequencies to lead

**Table 3 Accumulated Journal Citation Ratio Distribution**

Accum	TotalCites	SubCites1	SubCites2	SubCites3	Cites1	Cites2	Cites3
<i>MS</i>	16680	5560	11120	16680	1	n	9.2n
<i>MISQ</i>	21298	7099	14198.6	21298	1	n	10.9n
<i>IEETSE</i>	39554	13184.6	26368	39552	1	n	9.7n
<i>ISR</i>	43733	14577.7	29155	43733	1	n	10.2n
<i>JMIS</i>	50573	16857.6	33715	50573	1	n	11.4n
<i>OrgSCI</i>	60667	20222	40444	60666	1	n	12n
<i>ASQ</i>	65935	21978	43956	65935	1	n	13n
<i>I&amp;M</i>	80366	26788.67	53577	80366	1	n	14.8n
<i>DS</i>	86904	28968	57936	86904	1	n	16n
<i>DSS</i>	92261	30753.7	61507	92261	1	n	16n



**Figure 4 Management Science Journal Citation**



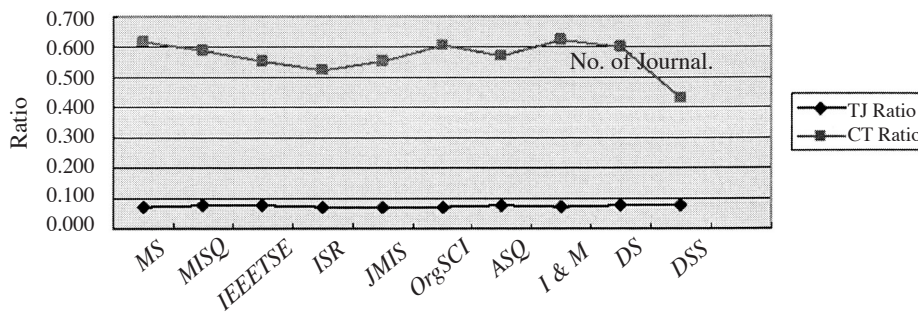
**Figure 5 Management Science Journal Citation**



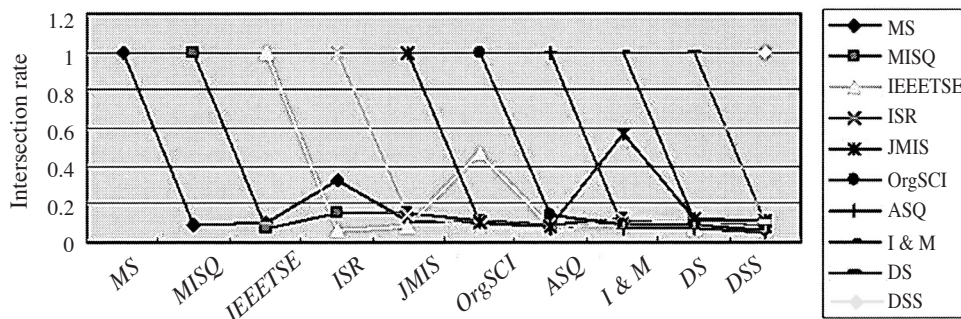
other journals. After calculating citation frequency, we rank all journals by its cited counts. In a result, we can get the Top 1 journal's starting point. The distribution for TJ and CT ratios are all illustrated in Figure 6. From Table 4 and Figure 6, we can see that the TJ ratio is quite stable at 0.07, and the CT ratio also has less variation. These ratios are helpful in deciding the core journal area or evaluating the distribution of experiment results.

**Table 4 TJ, CT Ratio and TP Slope for Ten Journals**

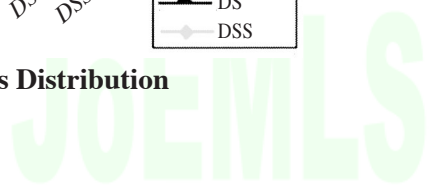
Journal	Turning Point	Journals Number	TJ Ratio	Citing Frequency	Total Citing	CT Ratio	Starting Point	TP Slope
MS	392	5442	0.072	10488	16906	0.62	1598	9.8
MISQ	122	1608	0.076	2739	4644	0.59	342	10.5
IEEETSE	569	7383	0.077	10217	18538	0.55	680	11.8
ISR	128	1758	0.073	2214	4217	0.53	212	12.2
JMIS	188	2628	0.072	3842	6930	0.55	309	12.4
OrgSCI	252	3457	0.073	6201	10259	0.60	487	11.8
ASQ	162	2064	0.078	3005	5268	0.57	472	9.9
I&M	338	4606	0.073	9080	14574	0.62	700	11.6
DS	159	2142	0.074	3975	6603	0.60	384	11.1
DSS	227	2873	0.079	2341	5458	0.43	175	11.9
Average			0.075			0.57		11.3



**Figure 6 The TJ and CT Ratio of Ten Journals**



**Figure 7 Journal Overlapping Weights Distribution**



**Journal Overlapping Analysis**

We develop the journal intersection rate in order to do the journal overlapping analysis. In Formula 1, both  $J_A$  and  $J_B$  include all the journal titles which came from the references in Journal A and B. Through intersection and union for both, we can know the overlapping situations between them. The score range is from 0 to 1, with higher score, more similar references. This is different from journal co-citation analysis because it is only concerned about intersections among journals.

$$\text{Journal intersection rate (JIR)} = (J_A \cap J_B) / (J_A \cup J_B) \dots \dots \dots (1)$$

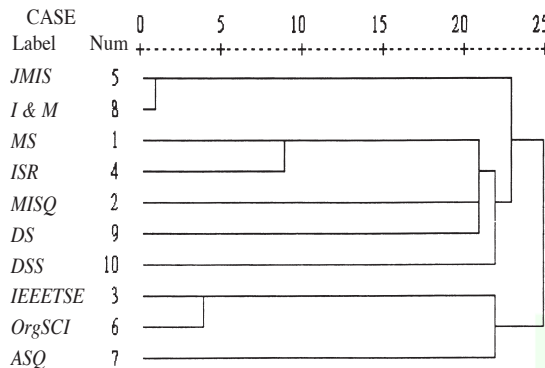
Hierarchical clustering is used in this paper. After processing the above JIR values, we get the cluster results shown in Figure 8. When similar an overlapping situation appears, these journals are clustered together. Based on this clustering result, a journal overlapping network can be constructed (Figure 9). This network can provide us a bird's eye view for all journals, which can help librarians to catalog and cluster journals. Also, students or junior researchers can get an associated journal link according to their interests.

**Table 5 The Overlapping Weights Table among Journals**

	<i>MS</i>	<i>MISQ</i>	<i>IEETSE</i>	<i>ISR</i>	<i>IMIS</i>	<i>OrgSCIA</i>	<i>SQ</i>	<i>I&amp;M</i>	<i>DS</i>	<i>DSS</i>
<i>MS</i>	1	0.09	0.10	0.33	0.11	0.11	0.07	0.11	0.12	0.09
<i>MISQ</i>		1	0.07	0.15	0.15	0.11	0.09	0.13	0.11	0.09
<i>IEETSE</i>			1	0.07	0.08	0.46	0.08	0.09	0.07	0.06
<i>ISR</i>				1	0.14	0.09	0.08	0.12	0.11	0.10
<i>JMIS</i>					1	0.10	0.08	0.57	0.12	0.12
<i>OrgSCI</i>						1	0.15	0.09	0.09	0.07
<i>ASQ</i>							1	0.07	0.08	0.05
<i>I&amp;M</i>								1	0.12	0.11
<i>DS</i>									1	0.10
<i>DSS</i>										1

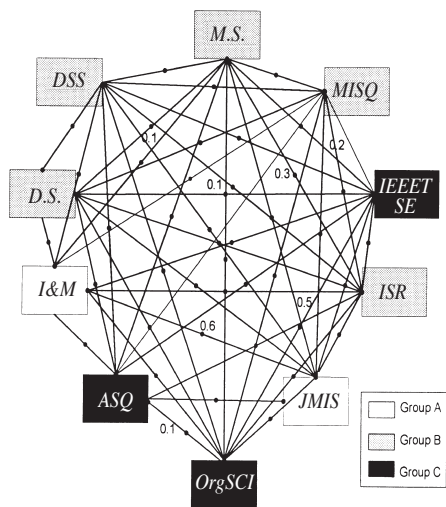
\*\*\*\*\*HIERARCHICAL CLUSTER ANALYSIS\*

Dendrogram using Average Linkage (between Groups)  
Rescaled Distance Cluster Combine



**Figure 8 Cluster Journal for Overlapping**

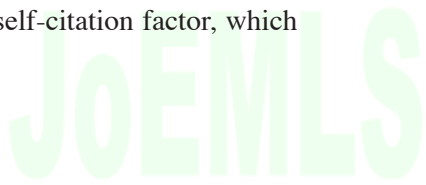




**Figure 9 Journal Overlapping Network**

**Journal Cited Analysis and Journal Citing Analysis**

Owing to the bi-directional citations between journals, we call this journal cited analysis and journal citing analysis. Similarly, it could be called as journal link in/out analysis. Four related factors are proposed in this article: **JCDF** (Journal Cited Factor), **SJCDF** (Subtract Self-Journal Cited Factor), **JCIF** (Journal Citing Factor) and **SJCIF** (Subtract Journal Citing Factor). In  $JCDF_k$  (Formula 2),  $DF_j$  is the abbreviation of Cited-Frequency, which counts the base journal's cited frequency (link-in) from "n" kinds of journals. In the citation matrix as Table 6,  $DF_j$  is the cited counts in the horizontal direction.  $DA_k$  is abbreviated from Cited-Articles, which it means the amounts of articles published by the base journal. And, "k" is the target journal, whose citation factor is being calculated. "n" is the total number of journals. "j" is the base journal index ( $j=1, \dots, n$ ). But while  $SJCDF_k$  (Formula 3) is being calculated, the situation for  $j=k$  must be skipped because its purpose is to eliminate noise coming from journal self-citation. The major difference between  $JCDF_k$  and  $JCIF_k$  (Formula 2 and 4) is that  $JCIF_k$  is for journal co-citing counts and another is for journal co-cited frequencies. For the direction in the citation matrix,  $JCDF_k$  is in the horizontal direction and  $JCIF_k$  is in the vertical direction. In,  $JCIF_k$ ,  $GF_j$  is abbreviated from Citing-Frequency, which counts the base journal's citing frequency (link-out) from "n" kinds of journals. In Table 6,  $GF_j$  is the citing counts in the vertical direction.  $GA_k$  is abbreviated from Citing-Articles, which it means the amounts of papers published by the journal "k".  $SJCIF_k$  (Formula 5) is similar to  $SJCIF_k$  by subtracting self-journal citation from  $JCIF$ . Usually, every journal has a higher self-citation factor, which can be found from Table 6.



$$JCDF_k = \frac{\sum_{j=1}^n (DF_j / DA_k)}{n} \dots\dots\dots(2)$$

$$SJCDF_k = \frac{\sum_{j=1}^{n-1} (DF_j / DA_k)}{n-1} \text{ where } j \neq k \dots\dots\dots(3)$$

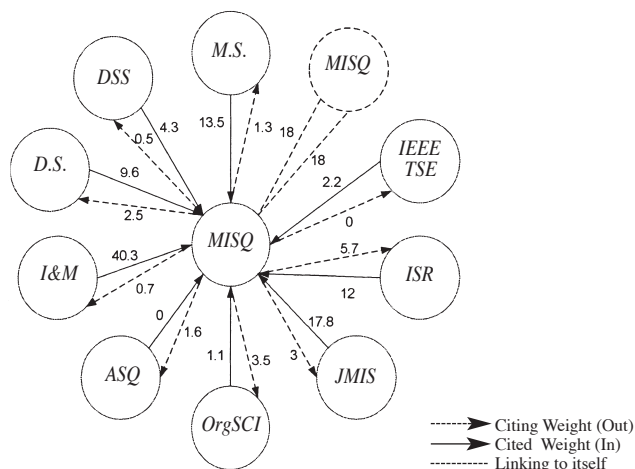
$$JCIF_k = \frac{\sum_{j=1}^n (GF_j / GA_j)}{n} \dots\dots\dots(4)$$

$$SJCIF_k = \frac{\sum_{j=1}^{n-1} (GF_j / GA_j)}{n-1} \dots\dots\text{where } j \neq k \dots\dots\dots(5)$$

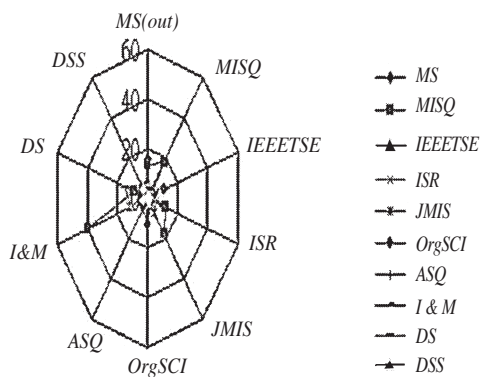
**Table 6 Journal Cited Factor (JCDF) and Journal Citing Factor (JCIF)**

	<i>MS</i>	<i>MISQ</i>	<i>IEETSE</i>	<i>ISR</i>	<i>IMIS</i>	<i>OrgSCIA</i>	<i>ASQ</i>	<i>I&amp;M</i>	<i>DS</i>	<i>DSS</i>	JCDF	SJCDF
<i>MS</i>	<b>15.4</b>	1.3	1.9	1.4	1.9	1.6	0.5	4.1	3.7	1.0	<b>3.3</b>	1.9
<i>MISQ</i>	13.5	<b>18.0</b>	2.2	12.0	17.8	1.1	0.0	40.3	9.6	4.3	<b>11.9</b>	11.2
<i>IEETSE</i>	0.2	0.0	<b>8.9</b>	0.1	0.3	0.0	0.0	0.4	0.1	0.3	<b>1.0</b>	0.2
<i>ISR</i>	6.8	5.7	0.8	<b>6.0</b>	4.6	0.5	0.0	7.7	2.0	1.8	<b>3.6</b>	3.3
<i>JMIS</i>	1.7	3.0	0.4	1.4	<b>7.1</b>	0.2	0.0	12.3	1.9	2.1	<b>3.0</b>	2.6
<i>OrgSCI</i>	5.0	3.5	11.1	1.4	3.1	<b>11.1</b>	2.9	4.4	2.1	0.6	<b>4.5</b>	3.8
<i>ASQ</i>	3.8	1.6	10.8	0.6	3.6	10.8	<b>4.9</b>	5.9	1.6	0.7	<b>4.4</b>	4.4
<i>I&amp;M</i>	0.8	0.7	0.1	0.7	2.2	0.0	0.0	<b>12.2</b>	0.6	0.9	<b>1.8</b>	0.7
<i>DS</i>	4.8	2.5	0.7	3.1	4.1	0.5	0.0	10.7	<b>14.8</b>	1.7	<b>4.3</b>	3.1
<i>DSS</i>	1.0	0.5	0.1	0.7	1.1	0.0	0.0	3.2	0.6	<b>4.1</b>	<b>1.1</b>	0.8
<b>JCIF</b>	<b>5.3</b>	<b>3.7</b>	<b>3.7</b>	<b>2.7</b>	<b>4.6</b>	<b>2.6</b>	<b>0.8</b>	<b>10.1</b>	<b>3.7</b>	<b>1.7</b>		
<b>SJCIF</b>	4.2	2.1	3.1	2.4	4.3	1.6	0.4	9.9	2.5	1.5		

After **JCDF**, **SJCDF**, **JCIF** and **SJCIF** were calculated, we proceed with further analysis. In Figure 10, the star topology of an individual journal like *MISQ* is obtained in order to understand how this journal links into or out to other journal. This provides us the detailed views for each journal. For Figure 11, we use radar graph to present the distance between journals. It provides another visualization way and global view for overall journals. Figure 12 uses both citing and cited factors to do hierarchical clustering. This journal citation cluster is a slightly different from journal overlapping cluster. The clustered journals would have similar linking weights to the other journals, but not similar overlapping rates. Related journal



**Figure 10 Star Topology of MISQ's Citation**



**Figure 11 Radar Graph of Distances between Journals**

reading suggestion, subscribing or classifying can become applications extending from this journal linking-in-out view. The cluster result can also be applied to construct a directional journal linking/citation network. In Figure 13, the same color means the same group of journals which were obtained from Figure 12. A bidirectional black arrow indicates strong coupling between two journals, but a gray arrow means a weak coupling. If two colors appear in the bidirectional arrow, the coupling strength between two journals is not very balanced. When the edge is a dotted line, the journal is in a one-way citation relationship. The journal linking network provides a global view for journal citation situation. To visit an individual node/journal, Figure 10 shows a zoom-in view for the detailed information about it.

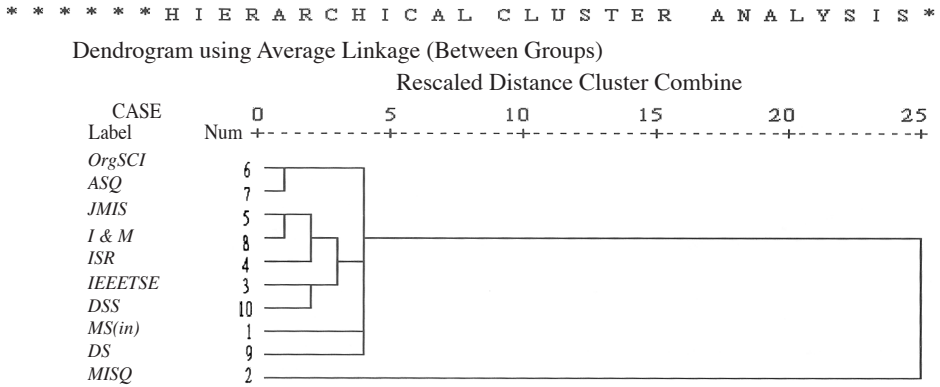


Figure 12 Clustering Journals for Link in/out Weight

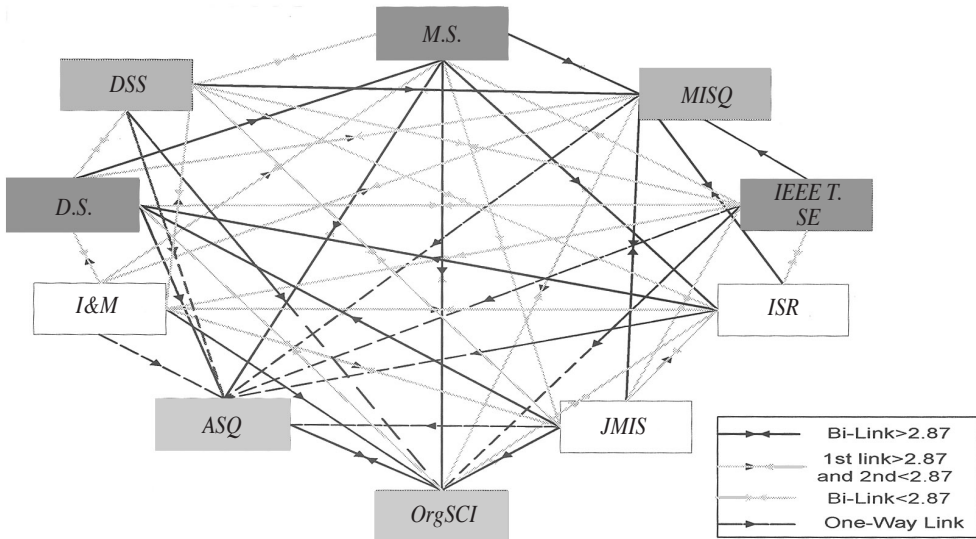


Figure 13 Journal Linking-in-out Network (journal cited/citing network)

**Departmental Core Journal Analysis**

The results for the new proposed two methodologies are discussed and analyzed in the followings.

**Citation analysis methodology**

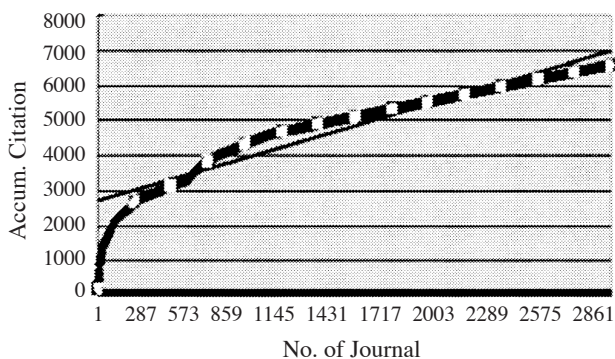
Through the JouRefs system, **JCDF** is used to proceed with citation calculation and analysis. For this, six departments were chosen including Library, MIS, English, Computer Science, Mechanical Engineering and Life science. Another interesting phenomenon was found. All citation distributions of the six departments have similar patterns as the individual/accumulated journals citations' distribution. Even the TJ ratio values illustrated in Table 7 and Figure 16 are also very stable and close to those in Table 4 and Figure 6. And the TJ ratio value is equal to



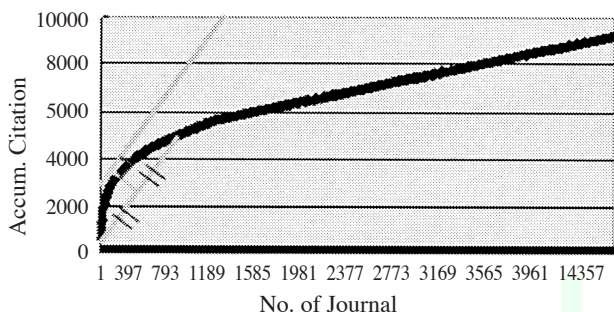
0.07 again. But the turning-point value and TP slope are slightly higher than before. Therefore, the TJ ratio is very suitable to decide which area is belonged to core journal segment. There are two approaches which were applied here in order to decide turning-point/threshold, linear regression (Figure 14) and geometric theory (Figure 15). The detailed algorithm can be reached at our supplemented website (Guo, 2004). Table 8 shows the top 45 journals collection for the MIS department. The complete ranking list for MIS and the other 5 departments are available on our website.

**Table 7 TJ, CT Ratio and TP Slope for Six Departments**

Dept	Turning Point	Journals Number	TJ Ratio	Citing Frequency	Total Citing	CT Ratio	Starting Point	TP Slope
Library	343	4625	0.074	4131	9228	0.448	555	11.90
MIS	216	2988	0.072	3016	6606	0.457	196	12.99
English	293	3927	0.075	1739	5782	0.301	74	13.20
CS	270	3561	0.076	2885	6818	0.423	127	12.77
Mech	175	2420	0.072	2878	5873	0.490	128	13.17
LifeSci	252	3394	0.074	9057	14662	0.618	747	10.55
Average			0.074			0.456		12.49



**Figure 14 Dept. of MIS Journal Citation**



**Figure 15 Dept. Lib & Info.Sci. Journal Citation**



**Table 8 Compare JCDF, LibJF and QJF (Hwang, 2001) through JCDF**

Journal Name	JCDF&Lib Stdev.	JCDF&Qq Stdev.	3Ways Stdev.	JCDF Value	JCDF Rank	LibJF Rank	QJF Rank	3Ways Avg.	3WAvg Rank
<i>MIS Quart</i>	0	0	0	9.33	1	1	1	1	1
<i>ACAD Manage Rev</i>	2.83	8.89	8.888	3.31	2	6	19	9	5
<i>Decision Sci</i>	21.2	16.5	16.52	2.53	3	33	6	14	7
<i>J Management Iiforma</i>	3.54	2.65	2.646	1.86	4	9	5	6	3
<i>Admin Sci Quart</i>	0	5.77	5.774	1.47	5	5	15	8.333	4
<i>Inform Syst Res</i>	2.83	2.31	2.309	1.46	6	2	2	3.333	2
<i>Inform Manage</i>	2.83	6.66	6.658	1.3	7	11	20	12.67	6
<i>ACAD Manage J</i>	10.6	7.55	7.55	1.3	8	23	14	15	8
<i>Information Systems</i>	1.41	82	81.99	1.29	9	7		55.33	15
<i>Res Organ Behav</i>	4.95	82.9	82.92	1.25	10	3		54.33	14
<i>Manage Sci</i>	14.8	15	14.98	1.01	11	32	3	15.33	9
<i>Commun Acm</i>	29.7	26.9	26.86	0.96	12	54	4	23.33	13
<i>Acm Comput Surv</i>	96.9	79.1	79.1	0.93	13		13	58.67	17
<i>J Manage</i>	3.54	77.1	77.12	0.92	14	19		61	19
<i>J Marketing</i>	7.78	81.3	81.3	0.9	15	4		56.33	16
<i>Decis Support Syst</i>	16.3	15.3	15.31	0.84	16	39	10	21.67	12
<i>Family Business Rev</i>	94	76.8	76.79	0.83	17			105.7	32
<i>J Marketing Res</i>	2.83	77.4	77.39	0.76	18	14		60.67	18
<i>ACM T Inform Syst</i>	92.6	75.6	75.63	0.75	19			106.3	33
<i>J Appl Psychol</i>	14.1	70	70	0.75	20	40		70	28
<i>Psychol Bull</i>	0.71	74.2	74.19	0.74	21	22		64.33	21
<i>J Computer Mediated</i>	90.5	73.9	73.9	0.73	22			107.3	34
<i>Sloan Manage Rev</i>	2.12	5.13	5.132	0.71	23	20	13	18.67	11
<i>J Am Soc Inform Sci</i>	89.1	72.7	72.75	0.67	24			108	35
<i>J Database Managemen</i>	88.4	71.9	71.88	0.67	25		26	67	25
<i>IEEE T Eng Manage</i>	12	67.2	67.22	0.65	26	43		73	29
<i>Organ Sci</i>	9.9	9.85	9.849	0.65	27	13	8	16	10
<i>Multimedia Syst</i>	86.3	70.4	70.44	0.64	28			109.3	36
<i>Int J Confl Manage</i>	85.6	69.9	69.86	0.63	29			109.7	37
<i>Pers Psychol</i>	0.71	69.6	69.57	0.58	30	29		69.67	27
<i>ACM T database Syst</i>	84.1	75.1	75.15	0.55	31		11	64	20
<i>Information Technolo</i>	9.9	72.5	72.51	0.52	32	18		66.67	24
<i>Int J Electron Comm</i>	14.8	74.4	74.36	0.52	33	12		65	22
<i>Prod Oper Manag</i>	82	67	66.97	0.5	34			111.3	38
<i>Small Gr Res</i>	14.8	61.2	61.24	0.44	35	56		80.33	30
<i>Strategic Manage J</i>	10.6	70.5	70.55	0.43	36	21		69	26
<i>J Org Comp Elect Com</i>	79.9	65.2	65.24	0.4	37			112.3	39

<i>J Retailing</i>	19.8	74.1	74.08	0.39	38	10	66	23
<i>Internet Res</i>	78.5	64.1	64.09	0.39	39		113	40
<i>J Bus Venturing</i>	77.8	63.5	63.51	0.37	40		113.3	41
<i>Hum Relat</i>	77.1	62.9	62.93	0.34	41		113.7	42
<i>J Manage Inform Syst</i>	76.4	62.4	62.35	0.33	42		114	43
<i>Comput Humanities</i>	75.7	61.8	61.78	0.33	43		114.3	44
<i>J Eng Technol Manage</i>	75	61.2	61.2	0.31	44		114.7	45
<i>Omega-Int J Manages</i>	1.41	60.1	60.05	0.31	45	47	80.67	31
Std Avg(Null=150)	37	53.1	53.12					

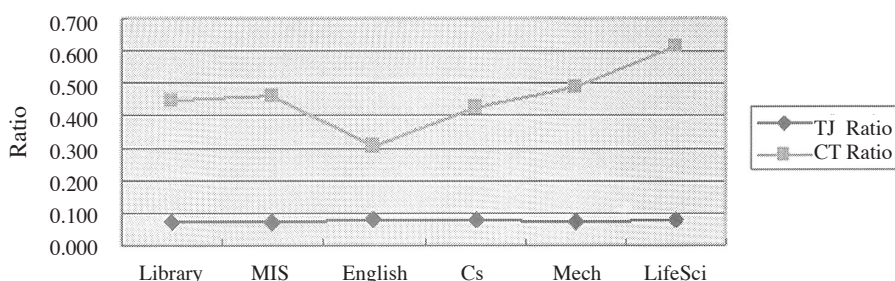


Figure 16 TJ and CT Ratio for Six Departments

### Library Web log analysis methodology

In this method, we used the library web log as the materials, and LibJF was developed and used in the JouWeb system, where LibJF means to use the library web log for departmental journal impact factor calculation. In Formula 6, the LibJF factor for base journal *j* can be obtained by letting query frequency (**QF<sub>j</sub>**) divide numbers of articles (**NA<sub>j</sub>**) published by the same base journal, so higher factors indicated more important journal. Noises in raw data are eliminated, such as biases from the same man querying the same journal many times or not researchers from MIS department making a query in the journal search engine. Only when on-line user's ip range belonged to the MIS departmental domain would it be counted.

$$\text{LibJF}_j = (\text{QF}_j / \text{NA}_j) * 10 \dots\dots\dots(6)$$

### Comparing Methodologies

In Table 9, we compare the four methodologies of Top 3 Universities, LibJF, QJF (We also call it questionnaire.) and JCDF. The top 3 Universities in MIS field are MIT, CMU and UT-Austin, as ranked by USNews.com (2004). Top3U means the situations for above university libraries subscribing print journals. The range is from 3 to 0, where the maximum value 3 means that all libraries have this journal in their collections. But this approach is limited in its ability to rank all journals. If a serial of famous journals were all subscribed to all

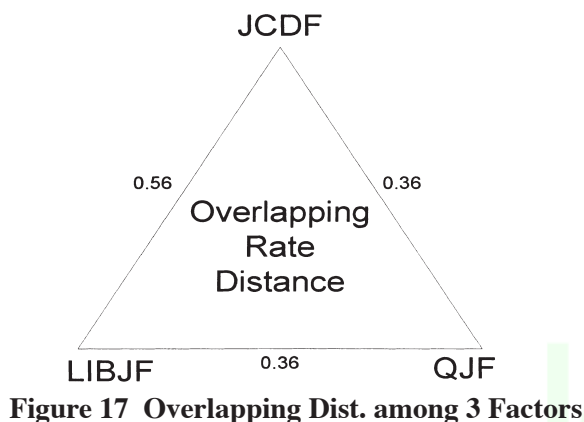
libraries, it would be difficult to give them the ranked weights. That is why we didn't rank and compare them in Table 9, even though we had collected these data.

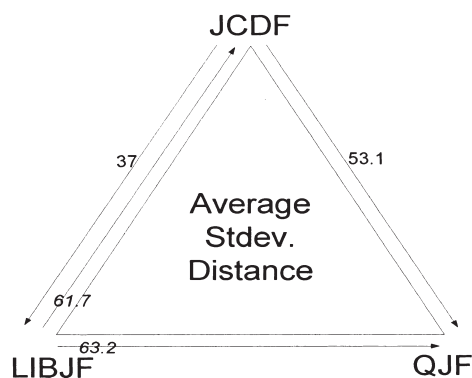
We applied two mathematical measures to show that both LibJF and JCDF are better than QJF (Questionnaire); they are Overlapping Rate and Average Standard Deviation distances. We use the MIS department as an example to explain them. For the LibJF, we rank them to compare with other factors below. As for the overlapping records under the top 45 journals, QJF-to-LibJF ratio is 16/45 and JCDF-to-LibJF ratio is 25/45, as seen in Table 9. And the JCDF-to-QJF ratio is 16/45 from Table 8. Therefore, LibJF is much more close to JCDF than QJF. We also use Average Standard Deviation Distance to see whether or not different methods have

**Table 9 Compare Top3 Univ, LibJF, QJF, and JCDF through LibJF**

Journal Name	LibJF	LibJF Rank	QJF Rank	JCDF Rank	lib&JCDF Stdev	lib&QJ Stdev	3Ways Stdv	3Ways Avg	3Ways AvgRn	Top3U Sum
<i>MIS Quart</i>	7.1	1	1	1	0	0	0	1	1	3
<i>Inform Syst Res</i>	5.8	2	2	6	2.83	0	2.309	3.333	2	3
<i>Res Organ Behav</i>	5	3		10	4.95	104	82.92	54.33	16	1
<i>J Marketing</i>	4.8	4		15	7.78	103	81.3	56.33	19	3
<i>ADminSci Quart</i>	4.7	5	16	5	0	7.78	6.351	8.667	4	3
<i>ACad Manage Rev</i>	4.2	6	19	2	2.83	9.19	8.888	9	5	3
<i>Information Systems</i>	4.2	7	5	9	1.41	1.41	2	7	3	3
<i>Market Sci</i>	3.9	8		47	27.6	100	73.36	68.33	26	3
<i>J Management Informa</i>	3.9	9		4	3.54	99.7	82.89	54.33	17	3
<i>J Retailing</i>	3.3	10		38	19.8	99	74.08	66	24	3
<i>Inform Manage</i>	3.3	11	20	7	2.83	6.36	6.658	12.67	6	2
<i>Int J Electron Comm</i>	3	12		33	14.8	97.6	74.36	65	23	2
<i>Organ Sci</i>	3	13	8	27	9.9	3.54	9.849	16	10	3
<i>J Marketing Res</i>	3	14		18	2.83	96.2	77.39	60.67	20	3
<i>Eur J Inform Syst</i>	2.9	15		84	48.8	95.5	67.51	83	35	2
<i>Inform Syst J</i>	2.5	16		137	85.6	94.8	73.9	101	44	2
<i>J ACAD Market Sci</i>	2.4	17		93	53.7	94	66.73	86.67	37	2
<i>Information Technolo</i>	2.4	18		32	9.9	93.3	72.51	66.67	25	0
<i>J Manage</i>	2.2	19		14	3.54	92.6	77.12	61	21	3
<i>Sloan Manage Rev</i>	2.1	20	13	23	2.12	4.95	5.132	18.67	11	3
<i>Strategic Manage J</i>	2	21		36	10.6	91.2	70.55	69	27	3
<i>Psychol Bull</i>	1.8	22		21	0.71	90.5	74.19	64.33	22	3
<i>ACAD Manage J</i>	1.7	23	15	2	14.8	5.66	10.6	13.33	7	3
<i>JBUS</i>	1.7	24		182	112	89.1	83.53	118.7	45	2
<i>J Manage Stud</i>	1.5	25		226	142	88.4	101.5	133.7	47	3
<i>Oper Res</i>	1.4	26	18	79	37.5	5.66	33.15	41	15	3
<i>J Pprod Innovat Manag</i>	1.4	27		405	87	301.7	259	52	3	

<i>J Financ</i>	1.4	28		119	64.3	86.3	63.41	99	43	3
<i>Pers Psychol</i>	1.2	29		30	0.71	85.6	69.57	69.67	28	3
<i>Calif Manage Rev</i>	1.1	30		110	56.6	84.9	61.1	96.67	41	3
<i>Commun Res</i>	1.1	31		64	23.3	84.1	61.44	81.67	33	3
<i>Manage Sci</i>	1.1	32	3	11	14.8	20.5	14.98	15.33	9	3
<i>Decision Sci</i>	1.1	33	6	3	21.2	19.1	16.52	14	8	3
<i>Am Sociol Rev</i>	1.1	34		72	26.9	82	59.14	85.33	36	3
<i>ACAD Manag Exec</i>	1.1	35		526	347	81.3	256.8	237	50	2
<i>J Financ Econ</i>	1	36		100	45.3	80.6	57.14	95.33	40	3
<i>J Consum Res</i>	1	37		58	14.8	79.9	60.1	81.67	34	3
<i>Harvard Bus Rev</i>	0.9	38	9	52	9.9	20.5	21.93	33	14	3
<i>Decis Support Syst</i>	0.9	39	10	16	16.3	20.5	15.31	21.67	12	3
<i>J Appl Psychol</i>	0.9	40		20	14.1	77.8	70	70	29	3
<i>Accounting Managemen</i>	0.9	41		526	343	77.1	254.5	239	51	0
<i>Am Psychol</i>	0.9	42		98	39.6	76.4	54.01	96.67	42	3
<i>IEEE T Eng Manage</i>	0.9	43		26	12	75.7	67.22	73	30	3
<i>Res Policy</i>	0.9	44		393	75	295.2	264.7	53	3	3
<i>J Poli Econ</i>	0.8	45		392	74.2	294.8	265	54	2	2
<i>J Accounting Res</i>	0.8	46		276	163	73.5	115.2	157.3	49	3
<i>Omega-Int J Manages</i>	0.8	47		45	1.41	72.8	60.05	80.67	32	3
<i>Psychol Rev</i>	0.6	48		73	17.7	72.1	53.16	90.33	38	3
<i>J Pers SocPsychol</i>	0.5	49		76	19.1	71.4	52.29	91.67	39	3
<i>Commun Acm</i>	0.5	50	4	12	26.9	32.5	24.58	22	13	3
<i>Small Gr Res</i>	0.4	51		35	11.3	70	62.29	78.67	31	2
<i>Organ Behav Hum Dec</i>	0.4	52	21	92	28.3	21.9	35.59	55	18	2
<i>Q J Econ</i>	0.3	53		201	105	68.6	75.18	134.7	48	3
<i>Eur J Oper Res</i>	0.2	54		192	97.6	67.9	70.74	132	46	3
Stdev Avg(QNF-Null=150, JCDF-null=600)					61.7	63.2	73.38			





**Figure 18 Avg Stdev Distance among 3 Factors**

similar ranking. In Figure 18, the distances from LibJF to JCDF and QJF are 61.7 and 63.2. And the distances from JCDF to LibJF and QJN are 37 and 53.1. QJF always has longer overlapping distances and shorter deviation distance to other nodes than JCDF and LibJF. So we can conclude that JCDF and LibJF are better than QJF. In order to deal with high deviations between journals caused by different methodologies, a simple ranking method is proposed here. By calculating the average from ranking results of previous 3 methods, we rank them again to generate new ranking numbers. The operator can choose to eliminate maximum or minimum value and then calculate average again. To sum up, Multi-methods can not only provide different views but also assist in double checking the ranking results. These proven methodologies and the computer-aided bibliometrics system can help researchers and librarians do more journal citation analysis effectively and efficiently reduce manual works.

### Conclusion

In this study, we propose two methodologies (JCDF and LibCF) and develop the DCABS system in order to generate the departmental core journal ranking list. Through comparing with questionnaire and Top universities' journal subscriptions by Overlapping Rate Distance and Average Standard Deviation Distance, we show that our two methods are much better than them. These two verified approaches not only generate two data sets but also help to double check the ranking lists each other. In addition, one departmental journal citation pattern was found. It is that the Ratio of Turning point-to-No. Journal was always around 0.07 among six departments. This would be helpful to determine or examine the core journal area or numbers for department. Combining methodologies with software system can reduce the manual works and increase the scale field experiments. Also it can avoid the error coming from careless operations and finish the jobs more efficiently and accurately.

## Acknowledgement

The Library Web log and Proxy Cache were kindly provided by W.S. Lian and Y.S. Fu. We would also like to thank Y.C. Lin and K.P. Pong for numerous stimulating discussions. This work was supported by a special fund from the National Science Council of Taiwan.

## References

- Barbara, S. S., et al. "Developing an Academic Medical Library Core Journal Collection in the Post-print Era: The Florida State University College of Medicine Medical Library Experience," *J Med Lib Assoc*, 91:3(2003): 292-302.
- Bill, C. H., & Kent, A. "Walstrom, Forum for MIS Scholars," *Communications of the ACM*, 40:11(1997).
- Bradford, S. C. *Documentation*. London: Crosby Lockwood & Sons, 1948.
- Bradford, S. C. "Sources of Information on Specific Subjects," *Engineering*, 137(1934): 85-86.
- Brookes, B. C. "The Derivation and Application of the Bradford-Zipf Distribution," *Journal of Documentation*, 24(1968): 247-265.
- Guo, G. M. 2004, 5/25-last update, *Author's Supplementary material*. Available: [www.openfind.idv.tw](http://www.openfind.idv.tw) (2004, 5/25).
- Hwang, S. Y., et al. "A Survey of Journal Publications of MIS Department in Taiwan," *Journal of Information Management*, 9:1(2001): 217-239.
- ISI Corp. 2004, 5/1-last update, *ISI Web of Knowledge*. Available: [www.isinet.com](http://www.isinet.com) (2004, 5/10).
- Janice, S. L., & John, D. M. "Defining the Undergraduate Core Journal Collection," *The Serials Librarian*, 43:1(2002): 45-59.
- Jeffrey, D. K., Kristin, H. G. & CyNthia, D. "A Method for Building Core Journal Lists in Interdisciplinary Subject Areas," *Journal of Document*, 54:4(1998): 477-488.
- Junping Q., et al. "The Course, Status quo and Trend of Bibliometrics in China," *Journal of Information, Communication and Library Science*, 9:1(2002): 1-11.
- Kobulnicky, P. J. "Physics libraries and literature," *Encyclopedia of Library and Information Sciences*, 22(1977): pp. 202-221.
- Leslie K. W. "Exciting Potential of Scholarly Electronic Journals," *CAUT Bulletin*, 43:7(1996): 9-15.
- NCU Library. 2004, 2/18-last update, *Journal search engine in NCU library website*. Available: [dns1.lib.ncu.edu.tw/~collin/carry/title.php](http://dns1.lib.ncu.edu.tw/~collin/carry/title.php) (2004, 5/1).
- Squid Cache, *Squid Web Proxy Cache*. Available: [www.squid-cache.org](http://www.squid-cache.org) (2004, 4/10).
- USNews.com, 2004, 5/20-last update, American Colleges Ranking, Available: [www.usnews.com/usnews/rankguide/rghome.htm](http://www.usnews.com/usnews/rankguide/rghome.htm) (2004, 3/25).
- Zipf G. K. *Human Behavior and the Principle of Least Efforts: An Introduction to Human Ecology*, Addison Wesley, (1949).
- Zhiren Z. "On the Characteristic Chinese Database: Chinese Social Science Citation Index," *Journal of Information, Communication and Library Science*, 9:1(2002): 57-61.

JoEMLS

<http://research.dils.tku.edu.tw/joemls/>